

**LBS**

**ø 20-51**

Seite  
Page  
Page



LBS-Grundaufnahmen  
LBS-Toolholders  
LBS Mandrins de base

40 - 41



Hartmetall-Bohrstangen  
Carbide boring bars  
Barres d'alésage en métal dur

42 - 43

## LBS-Grundaufnahmen

LBS-Toolholders

LBS-Mandrins de base

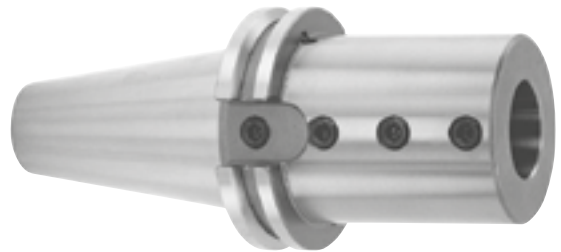

### Grundaufnahmen DIN 69871



Toolholders DIN 69871

Mandrins de base DIN 69871

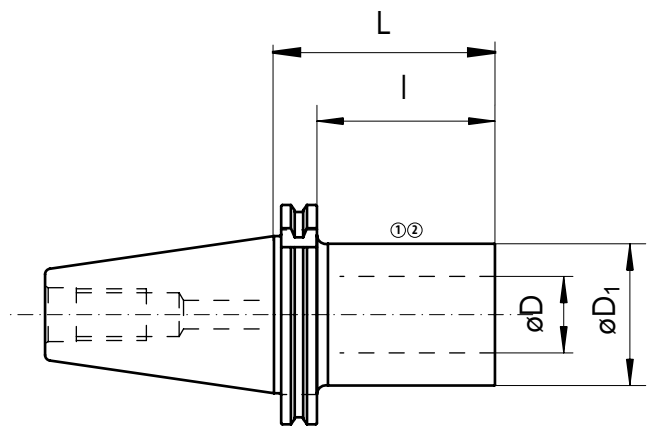
Bestell-Nr. Order No. No de cde	L	I	D	D <sub>1</sub>		MCC
LD10 41 18 042	61	42	18.5	44	DIN 69871-A/40	ZS18,5
LD10 43 18 042	61	42	18.5	44	DIN 69871-B/40	ZS18,5
LD10 50 18 060	79	60	18.5	44	DIN 69817-A/50	ZS18,5
LD10 53 18 060	79	60	18.5	44	DIN 69871-B/50	ZS18,5
LD10 41 25 059	79	59	25	49	DIN 69871-A/40	ZS25
LD10 43 25 059	79	59	25	49	DIN 69871-B/40	ZS25
LD10 50 25 078	98	78	25	49	DIN 69871-A/50	ZS25
LD10 53 25 078	98	78	25	49	DIN 69871-B/50	ZS25
LD10 50 32 095	114	95	32	60	DIN 69871-A/50	ZS32
LD10 53 32 095	114	95	32	60	DIN 69871-B/50	ZS32



### Ersatzteile / Spare parts / Pièces de rechange

øD		
18,5	G00 02 05	C00 96 10
25	G00 02 05	C00 96 10
32	G00 02 06	C00 96 11

## LBS-Grundaufnahmen

LBS-Toolholders

LBS-Mandrins de base

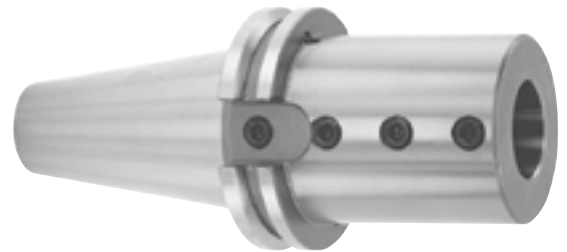

### Grundaufnahmen MAS-BT

Toolholders MAS-BT

Mandrins de base MAS-BT

Bestell-Nr. Order No. No de cde	L	I	D	D <sub>1</sub>		MCC
LT10 41 18 040	67	40	18,5	44	MAS-BT-A/40	ZS18,5
LT10 43 18 040	67	40	18,5	44	MAS-BT-B/40	ZS18,5
LT10 51 18 060	98	60	18,5	44	MAS-BT-A/50	ZS18,5
LT10 53 18 060	98	60	18,5	44	MAS-BT-B/50	ZS18,5
LT10 41 25 057*	84	57	25	49	MAS-BT-A/40	ZS25
LT10 43 25 057*	84	57	25	49	MAS-BT-B/40	ZS25
LT10 51 25 078	116	78	25	49	MAS-BT-A/50	ZS25
LT10 53 25 078	116	78	25	49	MAS-BT-B/50	ZS25
LT10 51 32 095	133	95	32	60	MAS-BT-A/50	ZS32
LT10 53 32 095	133	95	32	60	MAS-BT-B/50	ZS32

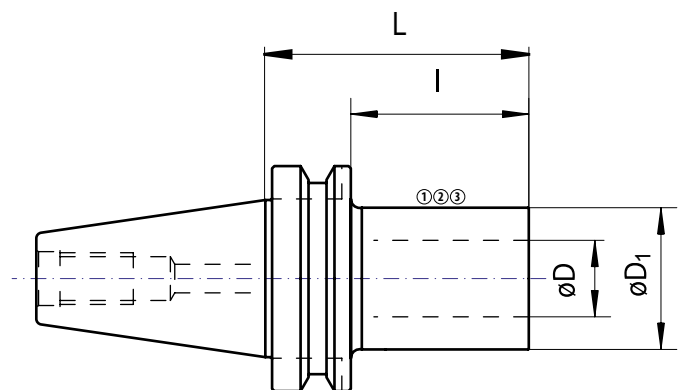

### Grundaufnahmen HSK

Toolholders HSK

Mandrins de base HSK

Bestell-Nr. Order No. No de cde	L	I	D	D <sub>1</sub>		MCC
LH10 63 18 101	127	85	18,5	44	HSK 63-A	ZS18,5
LH10 63 25 117	143	101	25	49	HSK 63-A	ZS25
LH10 100 18 107	152	107	18,5	44	HSK 100-A	ZS18,5
LH10 100 25 159	204	159	25	49	HSK 100-A	ZS25
LH10 100 32 170	215	170	32	60	HSK 100-A	ZS32

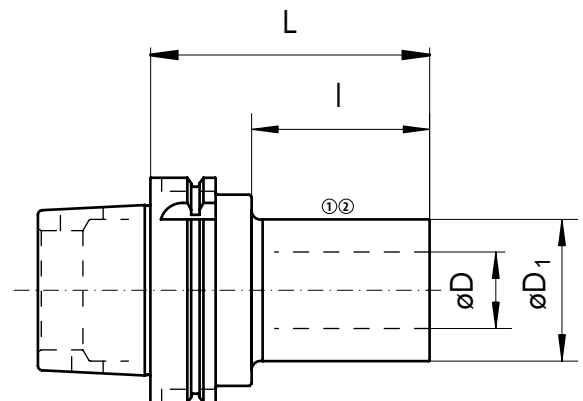

### Ersatzteile / Spare parts / Pièces de rechange

øD	①	②	* ③
18,5	G00 02 05	C00 96 10	
25	G00 02 05	C00 96 10	Z00 10 91
32	G00 02 06	C00 96 11	

## Hartmetall-Bohrstangen

Carbide boring bars

Barres d'alésage en métal dur



### Hartmetall-Bohrstangen

Carbide boring bars

Barres d'alésage en métal dur

Alpha	Bestell-Nr. Order No. No de cde	A <sub>min</sub> - A <sub>max</sub>	L	I	D	kg	SW	MCM	MCC
18,5	H06 18 A18 200	20 - 30	200	139 - 185	18,5	0,65	17	Z518,5	18,5
25	H06 25 A24 234	29 - 39	234	167 - 209	25	1,4	22	Z525	24,5
25	H06 25 A24 276	29 - 39	276	209 - 251	25	1,7	22	Z525	24,5
32	H06 32 A32 351	38 - 51	351	240 - 320	32	3,5	27	Z525	32

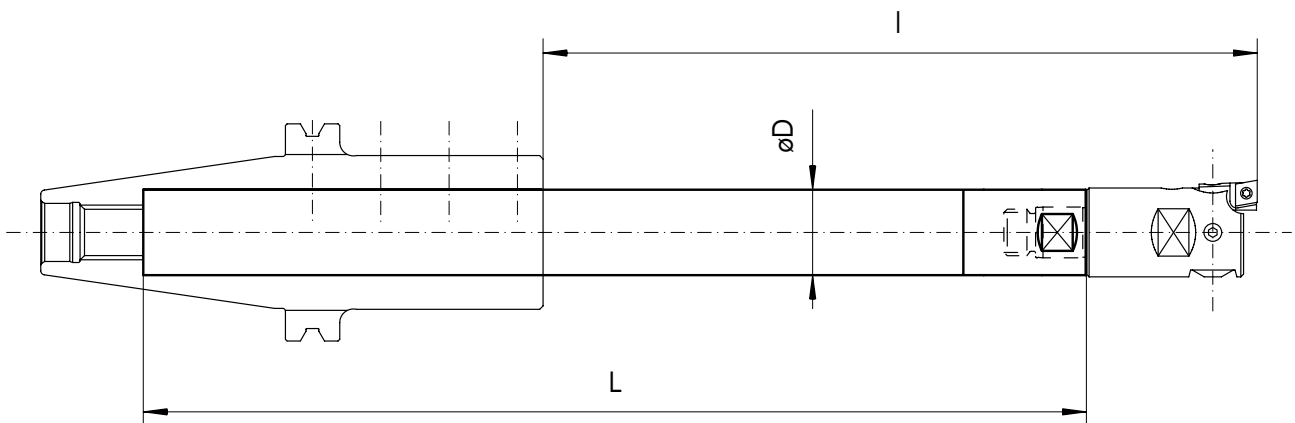

Das LBS-System ist sowohl zum Schlichten als auch zum Schruppen einsetzbar

Passende Feinbohrköpfe Seiten 32 und 34  
Zweischneider Schruppköpfe Seite 26

The LBS-System is suitable for both roughing and finishing

Suitable fine boring heads see pages 32 and 34  
Double cutter roughing heads see page 26

Le système LBS convient pour l'ébauche et la finition

Les têtes micrométriques voir pages 32 et 34  
Têtes à deux coupes pour l'ébauche voir page 26

## Hartmetall-Bohrstangen

Carbide boring bars  
Barres d'alésage en métal dur



### Hartmetall-Bohrstangen

Carbide boring bars  
Barres d'alésage en métal dur

Beta	Bestell-Nr. Order No. No de cde	A <sub>min</sub> - A <sub>max</sub>	L	I	D	kg	SW	MCM	MCC
25	H06 25 B25 234	29 - 39	234	167 - 209	25	1,4	22	ZS25	B25
25	H06 25 B25 276	29 - 39	276	209 - 251	25	1,7	22	ZS25	B25
32	H06 32 B32 351	38 - 51	351	240 - 320	32	3,5	27	ZS32	B32

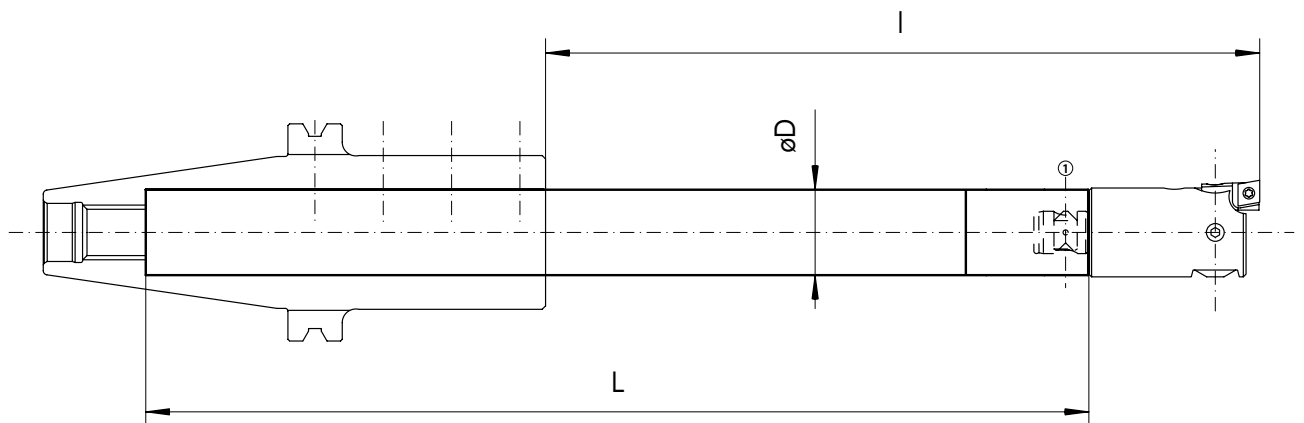

Das LBS-System ist sowohl zum Schlichten als auch zum Schruppen einsetzbar

Passende Feinbohrköpfe Seiten 33 und 35  
Zweischneider Schruppköpfe Seite 27

The LBS-System is suitable for both roughing and finishing

Suitable Fine boring heads see pages 33 and 35  
Double cutter roughing heads see page 27

Le Système LBS convient pour l'ébauche et la finition

Les têtes micrométriques voir pages 33 et 35  
Têtes à deux coupes pour l'ébauche voir page 27

### Ersatzteile / Spare parts / Pièces de rechange

Beta



25	Z00 25 24
32	Z00 32 24